

# XK3118T1 Technical Manual

## I. Main Technical Parameter:

**AD Switch Mode:**  $\Sigma-\Delta$  , 10times per second

**Load Cell Excitation:** DC +5V , can connect with 1-6pcs 350  $\Omega$  strain gauge load cell.

**Signal Input Range:** -16mV ~ 18mV ;

**Input Sensitivity** $\geq 1.5\mu V/e$

**Load Cell Connection:** Adopts 6 wire type (Long wire auto compensation)

**Indicator Power Supply :** AC 110 ~ 240V , 50 ~ 60Hz ; inbuilt 6V/4AH maintenance-free lead-acid battery

**Working Temperature :** 0~40°C。

## II. Connection with Load Cell:

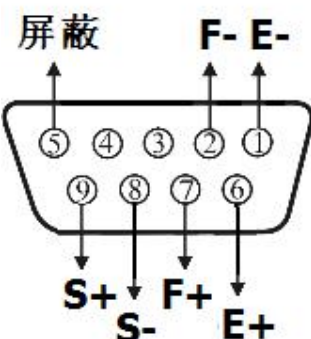
	Assignment	
	①	-Excitation
	②	-Feed Back
	⑥	+Excitation
	⑦	+Feed Back
	⑧	-Signal
	⑨	+Signal
	⑤	Shield Wire

Short connect PIN 1 and 2, PIN 6 and 7 when connected a load cell with 4 wire cable;

▲! Connection between load cell and indicator must be reliable, shield wire must be connected to ground reliably. Connection or disconnection are not allowed when the indicator is on, which may damage the indicator or load cells.

▲ ! Static protection must be properly adopted as the load cell and indicator are all static sensitive equipments. Welding or other strong electricity operation should be strictly forbidden. During thunderstorm season, proper lightning

protection should be taken care of to protect the load cells and indicators from damaging by lightening and to ensure the personal safety and the safely running of the weighing and related equipments.

### III. Calibration

Turn on the indicator, after self check it will enter normal weighing display. Warm up for 15~30 minutes and open the calibration cover in the back side of the indicator. The calibration status will be entered after pressing the calibration butto. Following are the details:

Steps	Operation	Display	Note
		<b>【 CAL 】</b>	Means calibration status has entered. Press "↙" for next step
1	"↑" to select division	<b>【 E 01 】</b>	<b>Divisions Setting:</b> 1、2、5、10、20、50
2	"↑" to select radix point "↙" to confirm	<b>【 dC 0 】</b>	<b>Radix Point Setting:</b> Indicator directly shows the Radix Point
3	Full Capacity Setting	<b>【 F030.00 】</b>	<b>Full Capacity Setting:</b> Press "→" the flash digit will move towards right Press "↑" to increase the number of flash digit Press "↙" to confirm and enter next step such as 3000
4	Press for confirm after date stable	<b>【 noLoAd 】</b>	<b>Zero Calibration:</b> Make indicator under noload status, press "↙" after date stable to confirm Zero
5	Input Loading Weight	<b>【 AdLoAd 】</b> After display for 2 seconds, auto switch to load input <b>【 003.000 】</b>	<b>Linearity Calibration:</b> Load weight, the closer to the full capacity the better. Operation is same as full capacity setting. Press "↙" to confirm and automatically exit calibration status 5 seconds after the stable indicator light on Such as: 3000
	Back to Working Status	<b>【 3.000 】</b>	After calibration, the current weight will be displayed

### IV. Setting for Other Calibraion Parameter

After enter the calibration status and display **【 CAL 】**, press "↑" and the indicator will display **【 Zero 】** and then press "↙" to enter setting for other calibration parameter.

Following are the details:

Steps	Operation	Display	Note
		<b>【 Zero 】</b>	Means other calibration parameter setting has entered. Press "↙" for next step
1	"↑" to switch "↙" to confirm	<b>【 Zot *.* 】</b>	<b>Zero Trace:</b> 0~4d
2	"↑" to switch "↙" to confirm	<b>【 nt ** 】</b>	<b>Manual Set Zero:</b> 0, 2, 4, 10, 20, 100 % of full capacity
3	"↑" to switch "↙" to confirm	<b>【 At ** 】</b>	<b>Auto Set Zero:</b> 0, 2, 4, 10, 20, 100 % of full capacity Select <b>【 -- 】</b> for turn off zero saving function, i.e. the last turn off zero that manually set will be the turn on zero when the indiator turn on next time and the auto zero will not be carried out again.
4	"↑" to switch	<b>【 FL *** 】</b>	<b>Filter:</b>



Keli Electric

			【Stb】: Stable 【SEn】: Sensitive
--	--	--	-----------------------------------